

## Standard colors KMS MD35 ECU wiring loom

Pin nr. KMS	Colour	Length	Diameter: 0,5mm <sup>2</sup>	Diameter: 0,75mm <sup>2</sup>	Function
1	red		*		CAN High
2	green		*		CAN Low
3	orange/black		*		Boost Control
4	yellow/red		*		Idle Control
5	white/black		*		Fuel pump relay
6	yellow/green		*		Diagnostic out / Ignition output 6
7	blue		*		Aux 1 out
8	pink		*		Aux 2 out
9	yellow/red		*		Aux 3 out
10	white/black			*	Power output2: Injector output 2 / A.L.S.
11	white			*	Injector output 1
12	red			*	12V injector supply
13	orange		*		Ignition output 1
14	green		*		Ignition output 2
15	purple		*		Ignition output 3
16	pink		*		Ignition output 4
17	blue		*		Ignition output 5
18	red/black		*		Tacho output
19	black		*		Sensor ground: water / air / MAP / TPS / etc.
20	yellow		*		5V sensor supply
21	yellow/black		*		Launch control
22	green/red		*		Powershift / Airco
23	black			*	ECU ground
24	orange/red		*		Analog aux 3: A.L.S. / launch / gearpos / map selector / EGT(1)
25	purple/red		*		Analog aux 2: A.L.S. / launch / gearpos / map selector / EGT(2)
26	pink/black		*		Oil pressure signal
27	grey/blue		*		Water temperature signal
28	red/blue		*		Air temperature signal
29	grey/black		*		MAP signal
30	grey		*		TPS signal
31	white		*		Lambda signal 1
32	white/red		*		Analog aux 1: Lambda signal 2 / gearpos / map selector
33	red		*		Crank-sensor signal inductive
34	red/green		* (shielded)		Hall input: Crank / Cam
35	red			*	12V ECU

For more information, user manuals, wiring examples and software see our website: <http://kms.vankronenburg.nl> or the software CD included with the ECU.

# MD35 main wiring

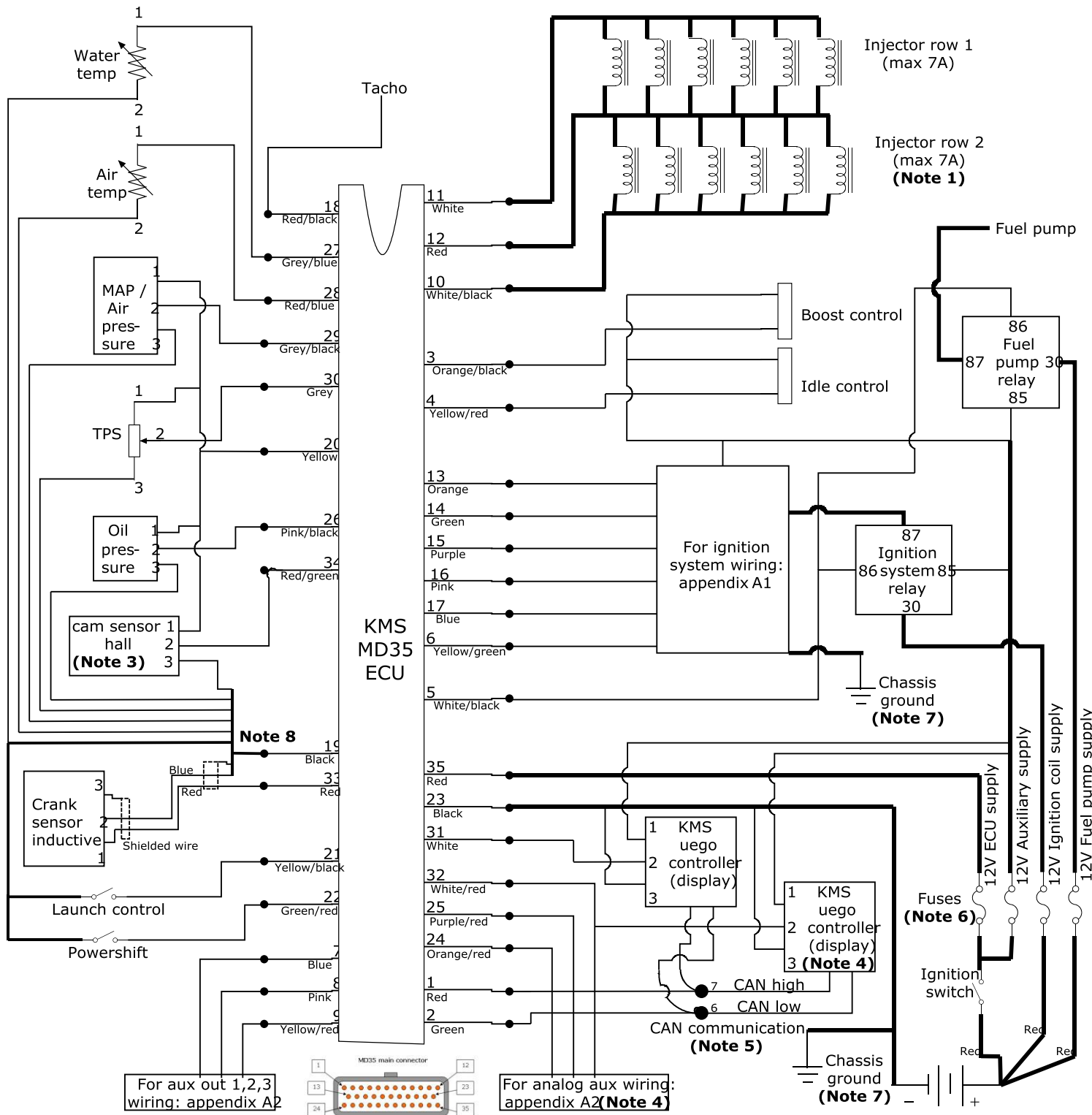

**Note 1:** A maximum of 6 high impedance injectors can be used on one injector output. When using low impedance injectors or more than 6 high impedance injectors on one injector output, an external KMS injection driver (2x10A) needs to be used. For connection of the injection driver, see wiring examples.

**Note 3:** A hall sensor can be used for measuring the cam position. Depending on the type of hall sensor being used, a 5 or 12V supply may be needed. When using a hall sensor as crank sensor, the hall sensor should be connected to the hall input (pin 34).

**Note 4:** Pin 32 can either be used for lambda signal 2 (KMS uego display/controller or standard lambda sensor) or an analog aux 1 function. See also the wiring examples.

**Note 5:** When using a KMS uego CAN controller/display, the controller/display can be connected to the MD35 via CAN communication.

**Warning:** When connecting multiple controllers on the CAN bus, the CAN wires must not be split/branched in a Y-shape to the connectors, only in serial configuration. See wiring examples for detailed drawings.

**Note 6:** The value/capacity of the fuse is dependent on the total maximum current of the electrical components connected. See wiring examples for more information.

**Note 7:** Preferably put all ground connections (except coil ground!) on the same chassis point, to prevent a difference in potential between the grounds.

**Note 8:** All sensor grounds (including the shield of the crankshaft wires) must be soldered together at one point as close as possible to the main connector. The connecting point should then be wired to the main connector by one single wire.